

CONTROLS

Technical Specification



Product Code: OVMS001WH

Luckinslive 407974111

Description: Surface Mounted 360° Low Profile Microwave Sensor White

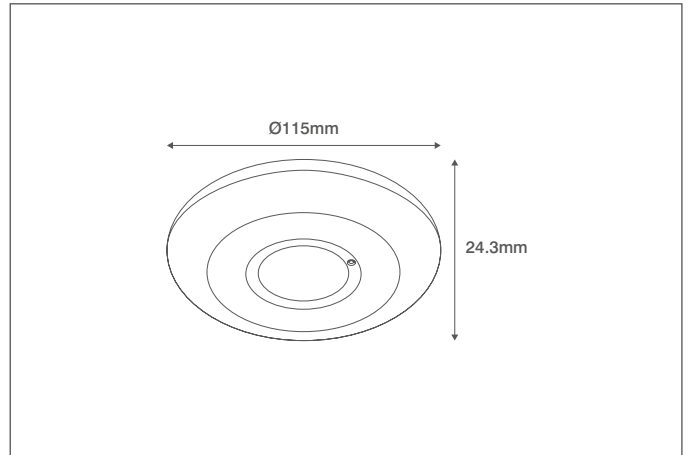

General Information

Dimensions (mm)	115 (Dia.) x 24.3 (D)
Materials	Body: Polycarbonate (UV Stabilised)
Colour	White
Product Weight (Kg)	0.11
Ingress Protection	IP20
Warranty (Years)	5

Supply & Power

Continuous Operating Voltage (AC) (Hz)	220-240 (50/60)
Terminations Input:	Permanent Live & Neutral
Output:	Switched Live (All Screw Terminals)
Safety Class	II
Load Rating - LED & CFL(W)	1000
Load Rating - Incan. & Halogen (W)	2000
Zero Cross Technology	Yes
Power Consumption	0.9

Sensor Parameters & Settings

Installation Height (m)	2 to up to 6	
Detection Diameter (m)	2 up to 16	
Detection Distance (m)	up to 6	
Detection Angle (°)	360	
Detection Motion Speed	0.6 to 1.5	
Manual Adjustments	Adjustment Type	Rotary Controls
	Time Delay	10 Seconds (Min. +3 Seconds) to 12 Minutes (Max. + 1 Minute)

Detection Area Schematics

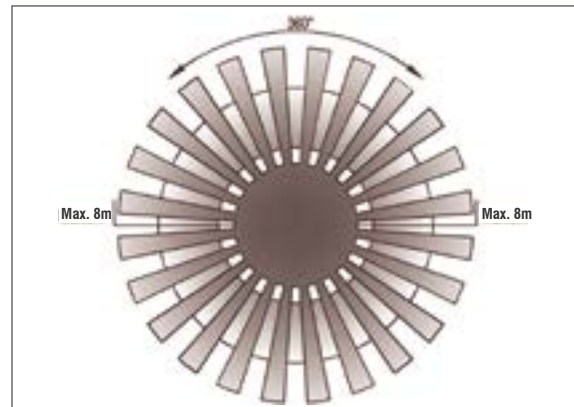
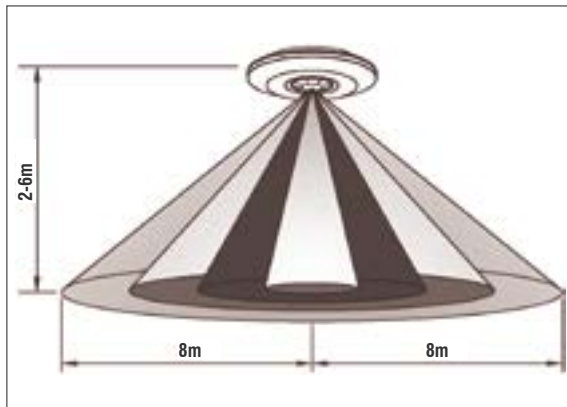

OVIA Limited, Scolmore House, Mariner, Lichfield Road Industrial Estate,
 Tamworth, Staffordshire, B79 7UL United Kingdom
 T: +44 (0)1827 300640
 E: sales@oviaUK.com | W: oviaUK.com



Catalogue



Section



DoC



Installation

