

# CONTROLS

## Technical Specification



Product Code: OVMS002WHD

Luckinslive 407974124

Description: Surface Mounted 360° 1-10V Dimmable Microwave Sensor IP65 White

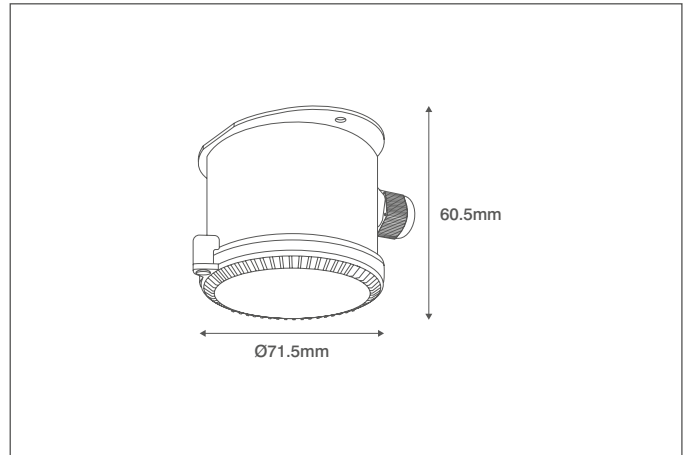

### General Information

Dimensions (mm)	71.5 (Dia.) x 90 (W) (With Mounting Base) x 60.5 (D)
Materials	Body: Polycarbonate (UV Stabilised)
Colour	White
Product Weight (Kg)	0.23
Ingress Protection	IP65
Warranty (Years)	5

### Supply & Power

Continuous Operating Voltage (AC) (Hz)	220-240 (50/60)
Terminations Input:	Permanent Live & Neutral Cables
Output:	Switched Live and 1-10V Dimming Cables
Safety Class	II
Load Rating - LED & CFL(W)	1000
Load Rating - Incan. & Halogen (W)	2000
Zero Cross Technology	Yes
Power Consumption	0.9

### Sensor Parameters & Settings

Dimmable / Format	Yes 1-10V	
Installation Height (m)	4 to up to 15	
Detection Diameter (m)	8 up to 20	
Detection Distance (m)	up to 15	
Detection Angle (°)	360	
Detection Motion Speed	0.6 to 1.5	
Manual Adjustments	Adjustment Type	DIP Switches
	Detection Range	50, 100
	Hold Time	5, 30, 90 Sec., 3, 5, 10, 20, 30 Mins.
	Stand-by Dimmed Level	10, 20, 30, 50

### Detection Area Schematics

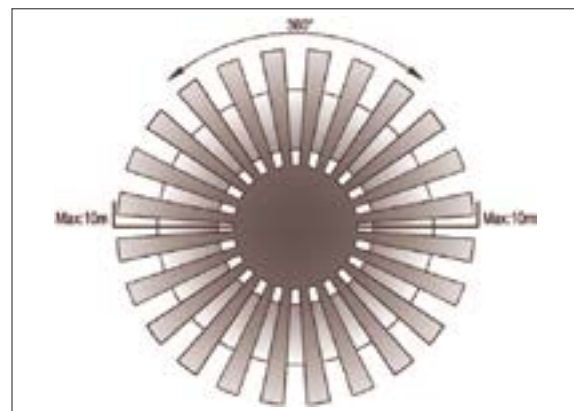
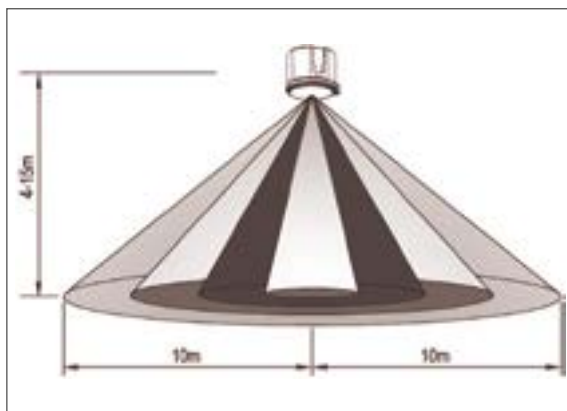

OVIA Limited, Scolmore House, Mariner, Lichfield Road Industrial Estate,  
 Tamworth, Staffordshire, B79 7UL United Kingdom  
 T: +44 (0)1827 300640  
 E: sales@oviaUK.com | W: oviaUK.com



Catalogue



Section



DoC



Installation

